

## CC2 Series

Compact Two-stage Cylinder Pressure Regulator



The CC2 Series compact two-stage precision pressure regulator is well suited for instrumentation applications requiring a precise and stable delivery pressure. This regulator was originally designed to meet the needs of the instrumentation industry; however, it would also be very useful in many other applications that require a compact two-stage pressure regulator to supply a precise delivery pressure with fluctuating supply pressures.

Another benefit of using the CC2 Series is that internally, it shares some of its design features and options with the time proven CPR-1 Series pressure regulator. These features and options allow the customer to essentially tailor this regulator to accommodate virtually any application requiring low to moderate flow rates. The unit will also be offered with inlet/outlet pressure gauges, CGA connections and relief valves.

The CC2 Series regulator is manufactured in aluminum as a standard option. Please consult GO Regulator for any optional materials of construction that might be required for toxic or corrosive process gas applications.

### Features & Specifications

- Compact size
- Two-stage regulation
- Stainless steel diaphragm
- Gas or liquid service
- Low internal volumes
- Maximum inlet pressure up to 3600 psig
- Outlet pressure ranges: 0–10 psig, 0–25 psig, 0–50 psig, 0–100 psig, 0–250 psig and 0–500 psig
- Cv flow coefficients: 0.06, 0.025, 0.2
- Leak rate, bubble-tight
- Operating temperatures: –40° F to +175° F (–40° C to +80° C)
- Inlet/outlet connections: 1/8" FNPT, 1/4" tube

pressure regulators

### GO Regulator

405 Centura Court • PO Box 4866 (29305) • Spartanburg, SC 29303  
Phone (864) 574-7966 Fax (864) 574-5608  
www.goreg.com • sales@goreg.com

# CC2 Series

## How to Order

Standard items in bold

**CC2 - 3 F 0 C 1 1 1 1** CGA Fitting **1 A 3 A 3**

### BODY MATERIAL

- 1 316L stainless steel
- 2 Brass
- 3 **Aluminum**

### PORT CONFIGURATIONS

#### F Standard

For more port configurations, see page 19.

### PROCESS PORT TYPES

#### (GAUGE PORT TYPE, IF NECESSARY)

- 0 1/8" FNPT (1/8" FNPT gauge ports)
- 2 1/4" tube stub, 2" long (1/8" FNPT gauge ports)

### OUTPUT RANGE

- C 0-10 psig
- D 0-25 psig
- E 0-50 psig
- G 0-100 psig
- I 0-250 psig
- J 0-500 psig

### DIAPHRAGM TYPE, 1<sup>ST</sup> STAGE

- 1 **Standard**

### DIAPHRAGM TYPE, 2<sup>ND</sup> STAGE

- 1 **Standard**

### CAP ASSEMBLY, 1<sup>ST</sup> STAGE

- 1 **Tamper-proof**
- 4 Tamper-proof, panel mount
- 5 Tamper-proof, captured vent

For a full list of options, visit the selection matrix for this product on [www.goreg.com](http://www.goreg.com)

### 2<sup>ND</sup> STAGE Cv FLOW

- 3 **0.06**
- 5 0.2
- C 0.025

### 2<sup>ND</sup> STAGE SEAT MATERIAL

- A **Tefzel®**
- H PCTFE (Formerly Kel-F81)
- Q PEEK™

### 1<sup>ST</sup> STAGE Cv FLOW

- 3 **0.06**
- 5 0.2
- C 0.025

### 1<sup>ST</sup> STAGE SEAT MATERIAL

- A **Tefzel®**
- H PCTFE (Formerly Kel-F81)
- Q PEEK™

### GAUGES

- 1 Include gauges
- 2 Omit gauges
- 3 Customer-supplied

### CGA FITTING

Use '000' to omit CGA  
Use 'CUS' for customer-supplied CGA

### CAP ASSEMBLY, 2<sup>ND</sup> STAGE

- 1 **Standard, aluminum**
- 4 Panel mount, aluminum
- 5 Captured vent, aluminum
- 7 Captured vent, stainless steel
- 8 Tamper-proof, aluminum
- 9 Fine adjust, 1/2" panel mount, aluminum
- 0 Fine adjust, 1 3/8" panel mount, aluminum
- D Captured vent, tamper-proof, stainless steel

## Maximum Temperature & Operating Inlet Pressures

SEAT MATERIAL	MAXIMUM TEMPERATURE	MAXIMUM OPERATING INLET PRESSURE
Tefzel®	150° F (66° C)	@ 3600 psig (24.82 MPa)
PEEK™	175° F (80° C)	@ 3600 psig (24.82 MPa)
PCTFE (formerly Kel-F® 81)	175° F (80° C)	@ 3600 psig (24.82 MPa)

NOTE: The choices above represent an abbreviated list of the more commonly ordered options. For a complete listing of all available options, please see the Selection Wizard on the GO website at [www.goreg.com](http://www.goreg.com) or contact the factory.

## Outline & Mounting Dimensions

Weight = 2.1 lbs (0.95 kg)

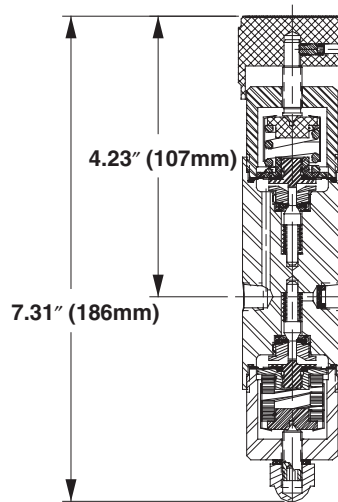
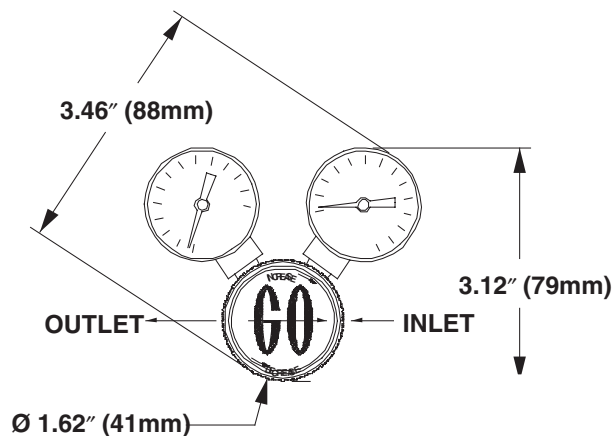

Weight - 2.1 lbs (0.95 kg)

Tefzel® is a registered trademark of the DuPont Company.  
Kel-F® is a registered trademark of 3M Company.  
PEEK™ is a trademark of Victrex PLC.

# Porting Configurations for Cylinder Regulators

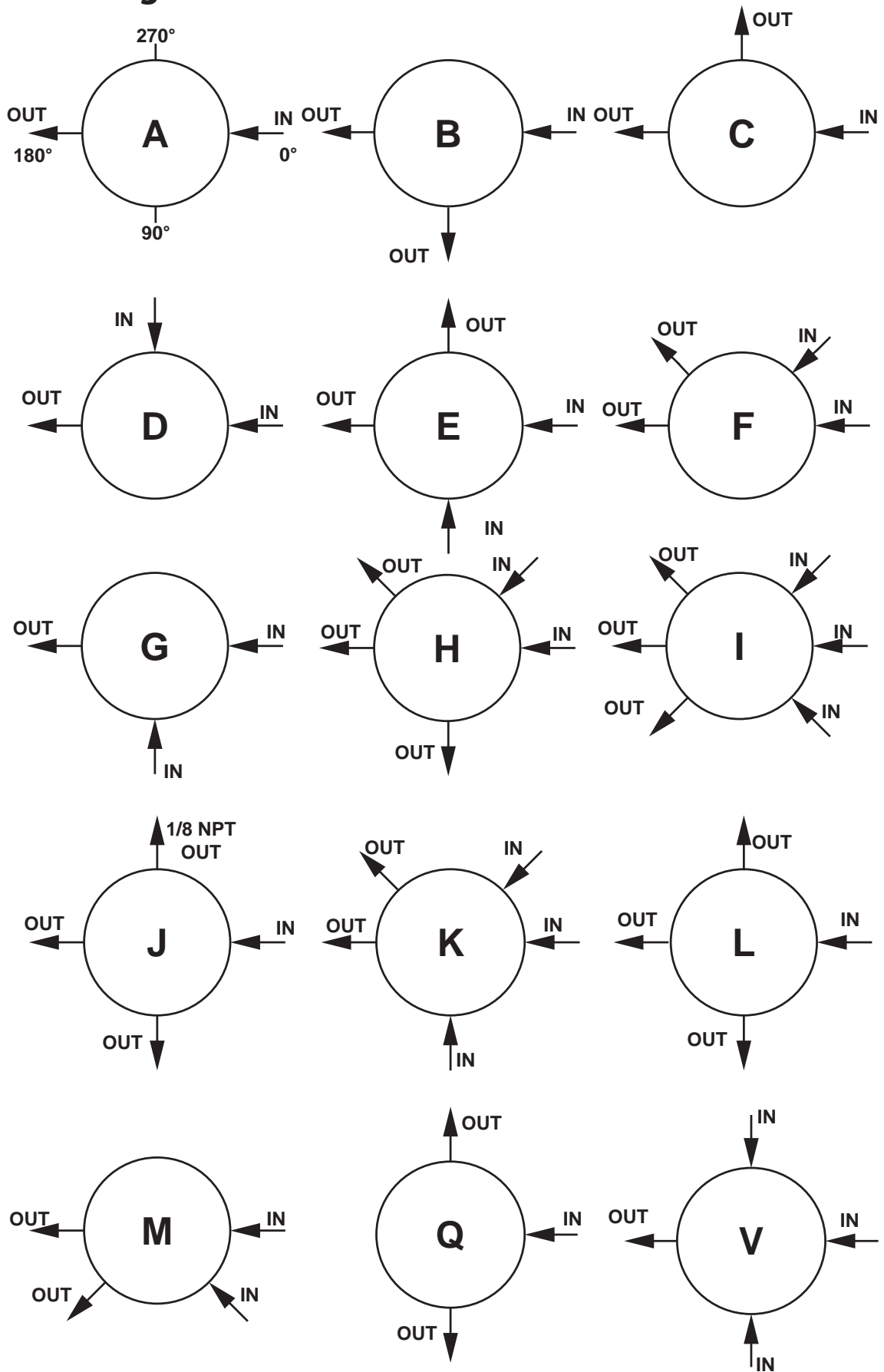

LOCATION OF PORTS FROM TOP VIEW