

**PR-50 Series High Pressure Regulator  
Non Self-Relieving Series  
Poppet, Seat & Spring Replacement Instructions**

**Make sure you thoroughly understand these directions before proceeding  
MAKE SURE THE REGULATOR IS DISCONNECTED FROM AIR SOURCE  
MAKE SURE ANY RESIDUAL PRESSURE IS BLEED OFF FROM REGULATOR.**

### Instructions

1. Completely read these instructions before performing any of the operations.
2. Make sure the regulator is disconnected from pressure source; make sure any residual pressure is bled off from the regulator. **FAILURE TO DO THIS WILL RESULT IN SERIOUS PERSONAL INJURY. DO NOT PROCEED UNTIL PRESSURE HAS BEEN REMOVED AND/OR TERMINATED**
3. Securely clamp the regulator body over the flats in a vise.
4. Turn the adjustment knob counterclockwise, as looking from the top of the regulator, until it will turn no further.
5. Using a 2 ¼" wrench, remove the spring housing assembly from the body.
6. Remove the range spring.
7. Remove the diaphragm assembly and counter spring.
8. Remove the seat retainer, seat, seat holder, lower flat seal, poppet and poppet spring.
9. Carefully remove large o-ring from regulator body.
10. Thoroughly blow out the inside of regulator body using clean, dry compressed air.
11. Clean seat surface with a cotton swab moistened with isopropyl alcohol.
12. Clean seat retainer of any foreign matter.
13. Place new poppet spring into .312 (7.9mm) hole in the body.
14. Place new poppet into poppet spring.
15. Install new lower flat seal into groove of new seat holder.
16. Install new seat into cavity of seat holder.
17. Place the seat holder over the nose of the poppet, with the seat facing up.
18. Place the seat retainer over the nose of the poppet and start the threads by hand. Tighten the seat retainer hand tight.
19. Finish tightening seat retainer to 25 lbf·ft (34 N·m). (15 lbf·ft (20 N·m) for brass body)
20. Attach primary pressure supply to inlet with suitable fittings.
21. Apply a small amount of leak detecting fluid, such as "Leak Detective" or soapy water, around poppet stem and seat retainer.
22. Slowly apply pressure to unit, watching closely for the presence of bubbles. Continue increasing inlet pressure up to one-half the maximum rated pressure for this unit. Let stand for 30 seconds. If there is evidence of leaking, such as bubbles or frothing, immediately relieve the primary pressure. The unit must be disassembled and inspected for foreign debris.
23. If there is no evidence of leaking, clean out the leak detecting fluid and proceed to the next step.
24. Apply o-ring lubricant, such as Krytox grease, into groove in regulator body if new o-ring is dark color. Do not

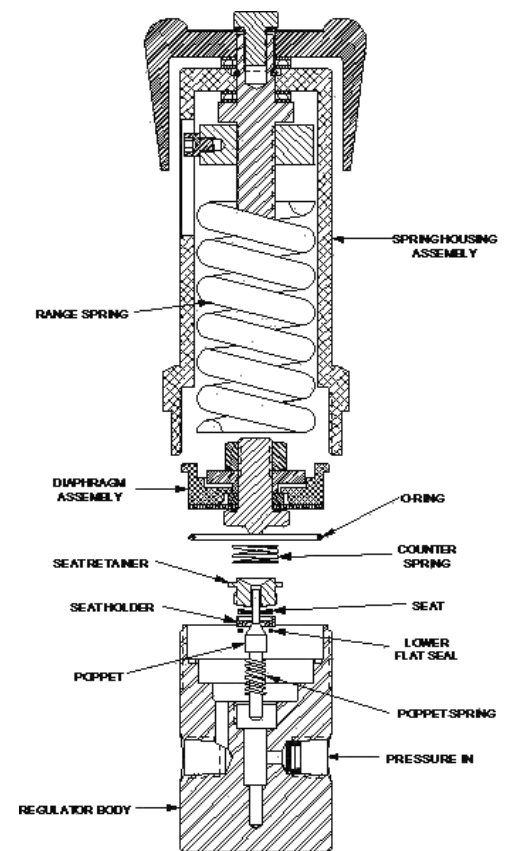

- apply lubricant to groove if new O-ring is white color. Install new O-ring into groove.
25. Place new counter spring onto seat retainer.
  26. Place diaphragm assembly into regulator cavity.
  27. Place range spring on the diaphragm assembly.
  28. Place a small amount of Krytox or other lubricant on the outer threads of the body.
  29. Put the spring housing assembly over the regulator and engage threads by hand. Tighten hand tight.
  30. Finish tightening spring housing assembly to 80 lbf•ft (108 N•m).
  31. Attach a pressure gauge and quarter-turn valve to the outlet port. Leave the valve in the closed position.
  32. Squirt a leak detecting fluid around the base of the spring housing assembly where it meets the body. Agitate the leak detecting fluid to form a foam. Apply this foam around the slot in the spring housing assembly while watching for signs of escaping gas.
  33. Slowly turn the knob while watching and listening for any leaks. It may be necessary to re-apply the liquid. If leaks are noticed, immediately back off adjusting screw and repair unit as needed.
  34. If no leaks are noticed, adjust control pressure to a value that is 110% of the maximum rating for this regulator. Reapply the leak detecting fluid as needed.
  35. Note the pressure reading on the gauge. Wait for 5 minutes. Increasing pressure indicates a leak across the seat or flat seal. Decreasing pressure indicates a possible diaphragm leak. If the pressure does not remain stable, the unit must be disassembled and the cause of leakage repaired.
  36. Relieve the outlet pressure while backing off on the adjusting knob. Continue backing off on adjustment knob until it is all the way out and will turn no further.
  37. The regulator is now ready for service.

---

## **GO Regulator**

405 Centura Court • PO Box 4866 • Spartanburg, SC 29303

Phone (864) 574-7966 • Fax (864) 574-5608

[www.goreg.com](http://www.goreg.com) • [sales@goreg.com](mailto:sales@goreg.com)