

# GO REGULATOR

## UCP-1 Series

Precision Pressure Regulator



The UCP-1 Series offers the user an ultra compact pressure regulator for use in high purity systems for the semiconductor industry. Meeting the highest purity standards and low particle generation of the semiconductor industry, this unit features internal components with standard surface finishes better than 25 Ra. The UCP-1 was computer designed to ensure a laminar flow transition from the flow control orifice to the outlet port. This design ensures virtually zero particle entrapment and efficient purge cycles.

### Features & Specifications

- 316 stainless steel construction
- Inlet 300 psig max. with Viton® or Kalrez® seats;  
3600 psig max. with Tefzel®, polyimide, or Kel-F® seats
- $1 \times 10^{-9}$  atm. cc/sec, inboard leak spec
- Outlet 10, 25, 50, 100, 250 and 500 psig
- Cv flow: 0.025, 0.06, or 0.2
- 1/4" male or female VCR®-compatible

### Applications

- Bulk inert gas distribution
- Diffusion furnaces
- Epitaxial reactors
- Specialty gas distribution
- Manufacturing tool

### Options

- Corrosion resistant materials of construction
- 15 Ra, 10 Ra, or 4 Ra internal surface finish

pressure regulators

#### GO Regulator

405 Centura Court • PO Box 4866 • Spartanburg, SC 29303

Phone (864) 574-7966 Fax (864) 574-5608

www.goreg.com • sales@goreg.com

# UCP-1 Series

## How to Order

### UCP1 -

#### BODY MATERIAL

- 1 316L stainless steel, standard

#### PORT CONFIGURATIONS

- A Standard

For more port configurations, see page 7.

#### PROCESS & GAUGE PORTS

- 1 ¼" FVCR process ports, ¼" FVCR gauge ports  
 2 ¼" FVCR process ports, ¼" MVCR gauge ports  
 4 ¼" swivel MVCR process ports, ¼" FVCR gauge ports  
 5 ¼" swivel MVCR process ports, ¼" swivel MVCR gauge ports  
 7 ¼" tube stubs at all ports, 3.43 end to end (1.000 stubs)  
 8 ¼" tube stubs at all ports, 7.43 end to end (3.000 stubs)  
 M ¼" fixed MVCR process ports, ¼" FVCR gauge ports  
 N ¼" fixed MVCR process ports, ¼" swivel MVCR gauge ports  
 O ¼" fixed MVCR process ports, ¼" fixed MVCR gauge ports

#### SEAT MATERIAL

- A Tefzel®  
 C Polyimide  
 H PCTFE (formerly Kel-F® 81)  
 I High density Teflon®  
 Q PEEK™

#### CAP ASSEMBLY

- 1 Standard, aluminum  
 4 Panel mount, aluminum  
 5 Captured vent, aluminum  
 7 Captured vent, stainless steel  
 B Fine adjust, 1⅜" panel mount, aluminum

#### O-RING/DIAPHRAGM BACKING

- 1 Teflon®/stainless steel  
 7 Viton®/stainless steel

#### DIAPHRAGM TYPE

- 1 Standard diaphragm  
 2 Diaphragm attached poppet

#### OUTLET RANGE

- C 0-10 psig  
 D 0-25 psig  
 E 0-50 psig  
 G 0-100 psig  
 I 0-250 psig  
 J 0-500 psig

#### FLOW COEFFICIENT (Cv)

- 3 0.06  
 5 0.2  
 C 0.025

#### SURFACE FINISH OF DIAPHRAGM CAVITY

- 1 < 25 Ra

NOTE: The choices above represent an abbreviated list of the more commonly ordered options. For a complete listing of all available options, please see the Selection Wizard on the GO website at [www.gore.com](http://www.gore.com) or contact the factory.

## Maximum Temperature & Operating Inlet Pressures

SEAT MATERIAL	MAXIMUM TEMPERATURE*	@	MAXIMUM OPERATING INLET PRESSURE
Tefzel®	150° F (66° C)	@	3600 psig (24.82 MPa)
High density Teflon®	150° F (66° C)	@	3600 psig (24.82 MPa)
PCTFE (formerly Kel-F® 81)	175° F (80° C)	@	6000 psig (41.37 MPa)
Polyimide	500° F (260° C)	@	3600 psig (24.82 MPa)
Polyimide	175° F (80° C)	@	6000 psig (41.37 MPa)
PEEK™	500° F (260° C)	@	3600 psig (24.82 MPa)
PEEK™	175° F (80° C)	@	6000 psig (41.37 MPa)

\* Temperatures in excess of 175° F (80° C) require the use of a metal knob or the tamper-proof option.

## Outline & Mounting Dimensions

Panel mount option requires 1.390 (35.3mm) minimum diameter panel cut out

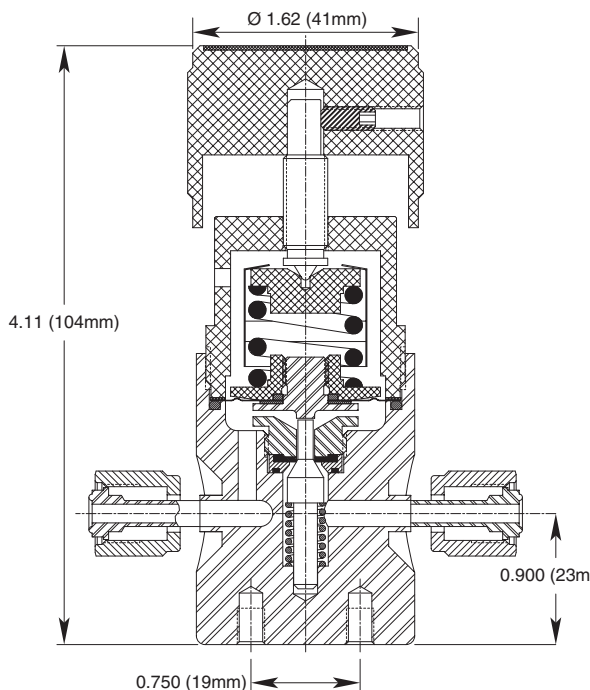

VCR® is a registered trademark of Cajon Co.

Hastelloy® is a registered trademark of Haynes International, Inc.

Teflon® and Tefzel® are registered trademarks of the DuPont Company.

Kel-F® is a registered trademark of 3M Company.

PEEK™ is a trademark of Victrex PLC.

# Porting Configurations for High Purity Pressure Regulators

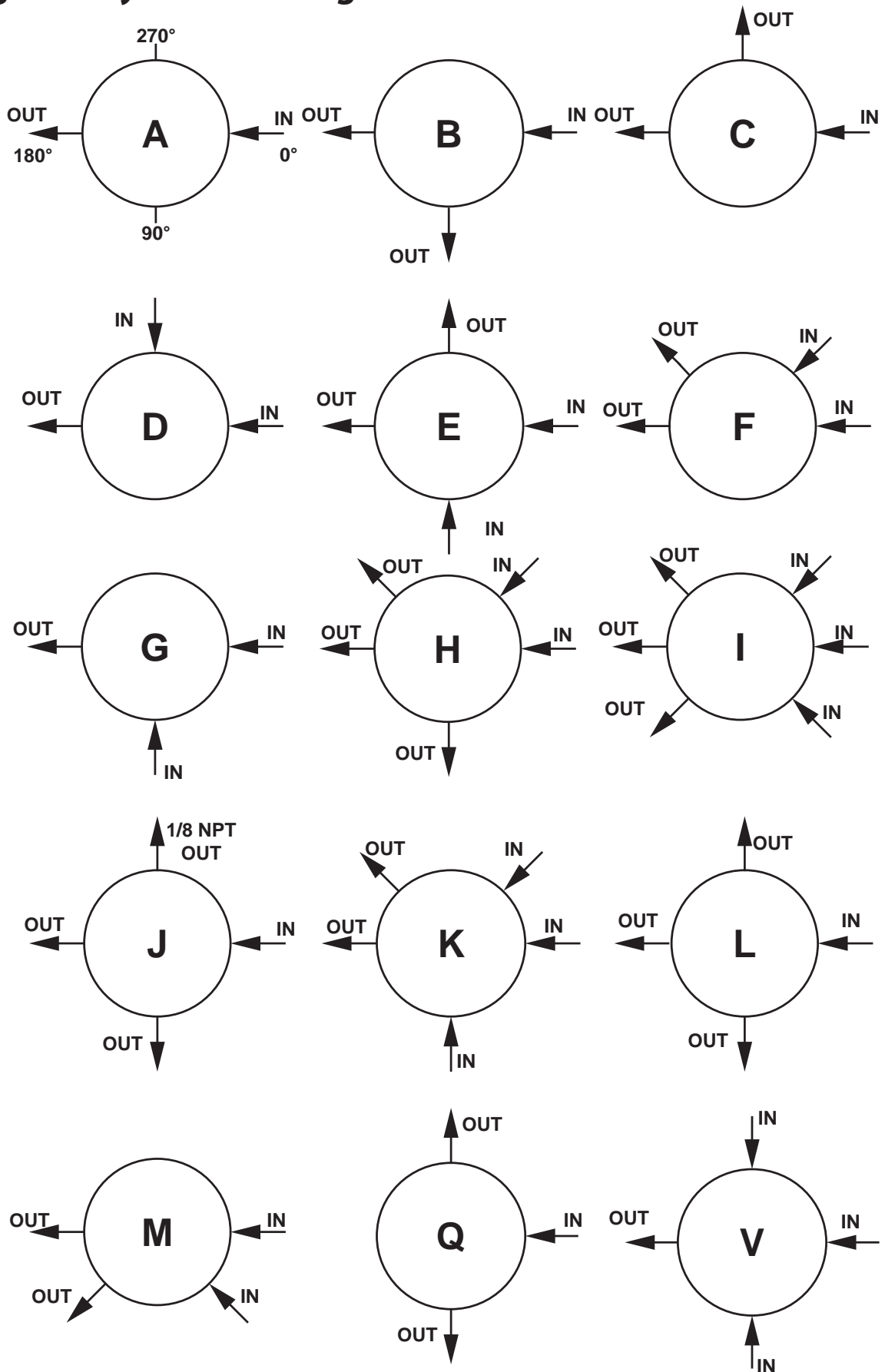

LOCATION OF PORTS FROM  
TOP VIEW