

# GO REGULATOR

## UPR-7 Series

High Flow Precision Pressure Regulator



The high flow coefficient of the UPR-7 provides the user with a high purity pressure regulator exhibiting very low droop characteristics. The combination of high flow and low droop makes the UPR-7 ideally suited for bulk gas distribution applications. The UPR-7 Series features fully electropolished internal components with standard surface finishes better than 25 Ra. This feature provides the semiconductor end-user with a precision pressure regulator, economically priced for applications ranging from gas distribution to point of use in the manufacturing tool.

### Features & Specifications

- 25 Ra internal surface finish, standard
- High flow, Cv 1.1
- Low droop characteristics
- 316L stainless steel body, cap, internals
- Male, female or internally machined VCR®-compatible ports
- $1 \times 10^{-9}$  atm. cc/sec, inboard leak spec

### Applications

- Bulk inert gas distribution
- Diffusion furnaces
- Epitaxial reactors
- Specialty gas distribution

### Options

- Wetted materials for corrosive service: Hastelloy®, Monel®

pressure regulators

### GO Regulator

405 Centura Court • PO Box 4866 • Spartanburg, SC 29303

Phone (864) 574-7966 Fax (864) 574-5608

www.goreg.com • sales@goreg.com

# UPR-7 Series

## How to Order

### UPR7 -

#### BODY MATERIAL

- 1 316L stainless steel
- 2 Hastelloy® C

#### PORT CONFIGURATIONS

- A Standard
- For more port configurations, see page 7.

#### PROCESS & GAUGE PORTS

- 3 ¼" FVCR process ports, ¼" IVCR gauge ports
- 4 ¼" swivel MVCR process ports, ¼" FVCR gauge ports
- 7 ¼" IVCR process ports, ¼" FVCR gauge ports
- A ⅜" FVCR process ports, ¼" FVCR gauge ports
- D ⅜" swivel MVCR process ports, ¼" FVCR gauge ports
- G ½" FVCR process ports, ¼" FVCR gauge ports
- I ½" FVCR process ports, ¼" IVCR gauge ports
- J ½" swivel MVCR process ports, ¼" FVCR gauge ports
- M ¾" FVCR process ports, ¼" FVCR gauge ports
- N ¾" swivel MVCR process ports, ¼" swivel MVCR gauge ports

#### SURFACE FINISH OF DIAPHRAGM CAVITY

- 1 < 25 Ra

#### SEAT MATERIAL

- A Tefzel®
- D Viton® (300 psig max. inlet)
- H PCTFE (formerly Kel-F® 81)
- I Teflon®
- K Kalrez® (300 psig max. inlet)
- Q PEEK™

#### CAP ASSEMBLY

- 1 Standard, stainless steel
- 2 T-handle, stainless steel
- 7 Captured vent, stainless steel
- 8 Tamper-proof, stainless steel

#### DIAPHRAGM FACING/BACKING

- 1 Teflon®/stainless steel
- 2 Teflon®/Viton®
- 6 Tefzel® ring/stainless steel
- 0 Teflon®/Hastelloy® C

#### DIAPHRAGM TYPE

- 1 Standard

#### OUTLET RANGE

- C 0-10 psig
- D 0-25 psig
- E 0-50 psig
- G 0-100 psig
- I 0-250 psig
- J 0-500 psig

#### FLOW COEFFICIENT (Cv)

- 5 0.2
- 8 1.1
- H 0.5

NOTE: The choices above represent an abbreviated list of the more commonly ordered options. For a complete listing of all available options, please see the Selection Wizard on the GO website at [www.goreg.com](http://www.goreg.com) or contact the factory.

## Maximum Temperature & Operating Inlet Pressures

### Up to 100 psig Outlet Pressure

SEAT MATERIAL	MAXIMUM TEMPERATURE*	@	MAXIMUM OPERATING INLET PRESSURE
Teflon®	150° F (66° C)	@	1000 psig (6.90 MPa)
Tefzel®	175° F (80° C)	@	3600 psig (24.82 MPa)
PCTFE (formerly Kel-F® 81)	175° F (80° C)	@	3600 psig (24.82 MPa)
PEEK™	250° F (121° C)	@	3600 psig (24.82 MPa)
Viton®	250° F (121° C)	@	300 psig (2.07 MPa)
Kalrez®	250° F (121° C)	@	300 psig (2.07 MPa)

### 0-250 psig Outlet Pressure (Hard Knob)

SEAT MATERIAL	MAXIMUM TEMPERATURE*	@	MAXIMUM OPERATING INLET PRESSURE
Teflon®	150° F (66° C)	@	500 psig (3.45 MPa)
Tefzel®	175° F (80° C)	@	500 psig (3.45 MPa)
PCTFE (formerly Kel-F® 81)	175° F (80° C)	@	500 psig (3.45 MPa)
Viton®	250° F (121° C)	@	300 psig (2.07 MPa)
Kalrez®	250° F (121° C)	@	300 psig (2.07 MPa)

### 0-250 psig & 0-500 psig Outlet Pressures (T-handle or Tamper-proof)

SEAT MATERIAL	MAXIMUM TEMPERATURE*	@	MAXIMUM OPERATING INLET PRESSURE
Teflon®	150° F (66° C)	@	1000 psig (6.90 MPa)
PEEK™	250° F (121° C)	@	3600 psig (24.82 MPa)

\* Temperatures in excess of 175° F (80° C) require the use of a metal knob or the tamper-proof option.

VCR® is a registered trademark of Cajon Co.  
 Hastelloy® is a registered trademark of Haynes International, Inc.  
 Monel® is a registered trademark of Special Metals Corporation.  
 Teflon® and Tefzel® are registered trademarks of the DuPont Company.  
 Kalrez® and Viton® are registered trademarks of DuPont Dow Elastomers.  
 Kel-F® is a registered trademark of 3M Company.  
 PEEK™ is a trademark of Victrex PLC.

## Outline & Mounting Dimensions

Panel mount option requires 1.390 (35.3mm) minimum diameter panel cut out

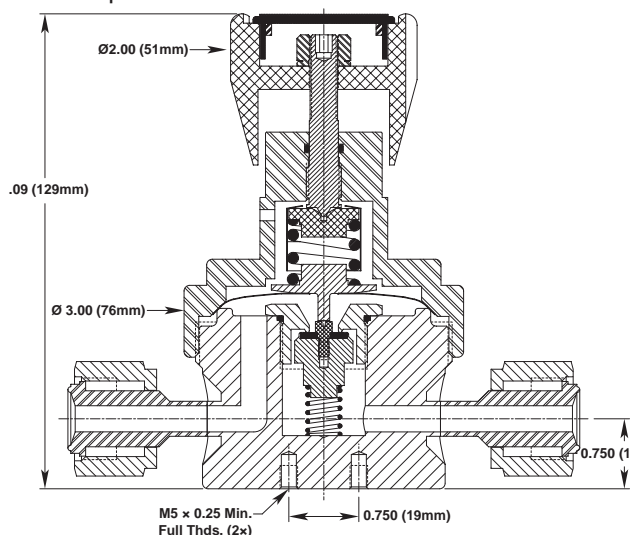

# Porting Configurations for High Purity Pressure Regulators

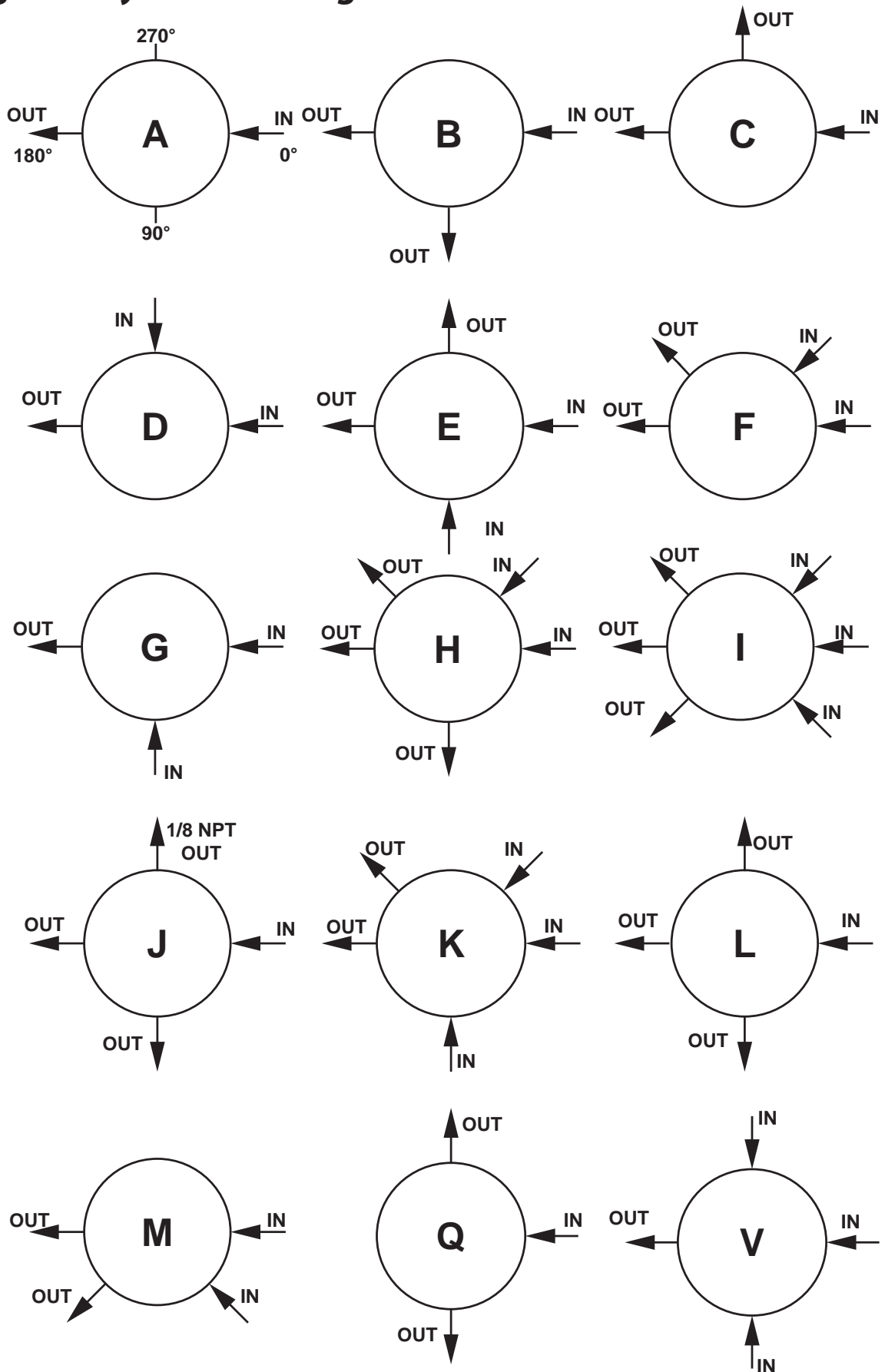

LOCATION OF PORTS FROM  
TOP VIEW