

PR-5 Series Pressure Regulator Poppet, Seat & Spring Replacement Instructions

Make sure you thoroughly understand these directions before proceeding
MAKE SURE THE REGULATOR IS DISCONNECTED FROM AIR SOURCE
MAKE SURE ANY RESIDUAL PRESSURE IS BLED OFF FROM REGULATOR.

Instructions

1. Completely read these instructions before performing any of the operations.
2. Make sure the regulator is disconnected from pressure source; make sure any residual pressure is bled off from the regulator. **FAILURE TO DO THIS WILL RESULT IN SERIOUS PERSONAL INJURY. DO NOT PROCEED UNTIL PRESSURE HAS BEEN REMOVED AND/OR TERMINATED**
3. Securely clamp the regulator over the flats in a vise.
4. Turn the adjustment knob counterclockwise, as looking from the top of the regulator, until it will turn no further.
5. Remove the pry-out plug from top of knob, remove knob nut and unscrew knob from adjusting screw.
6. Remove the cap and adjusting screw as a unit. The range spring will be securely held inside the cap if this unit is equipped with a spring stabilizer. Earlier models do not have a stabilizer, in which case the range spring will be sitting on top of the diaphragm.
7. Remove the diaphragm assembly.
8. Remove the seat retainer, seat holder, seat, lower flat seal, poppet and poppet spring.
9. Thoroughly blow out the inside of regulator body using clean, dry compressed air.
10. Clean seat surface with a cotton swab moistened with isopropyl alcohol.
11. Place new poppet spring into .312 (7.9mm) hole in the body.
12. Place new poppet into poppet spring.
13. Install new lower flat seal into groove of new seat holder.
14. Install new seat into cavity of seat holder.
15. Place the seat holder over the nose of the poppet, with the seat facing up.
16. Place the seat retainer over the nose of the poppet and start the threads by hand. Tighten the seat retainer hand tight.
17. Finish tightening seat retainer to 25 lbf·ft (34 N·m). (15 lbf·ft (20 N·m) for brass body)
18. Attach primary pressure supply to inlet with suitable fittings.
19. Apply a small amount of leak detecting fluid, such as "Leak Detective" or soapy water, around poppet stem and seat retainer.
20. Slowly apply pressure to unit, watching closely for the presence of bubbles. Continue increasing inlet pressure up to one-half the maximum rated pressure for this unit. Let stand for 30 seconds. If there is evidence of leaking, such as bubbles or frothing, immediately relieve the primary pressure. The unit must be disassembled and inspected for foreign debris. If there is no evidence of leaking, clean out the leak detecting fluid and proceed to the next step.

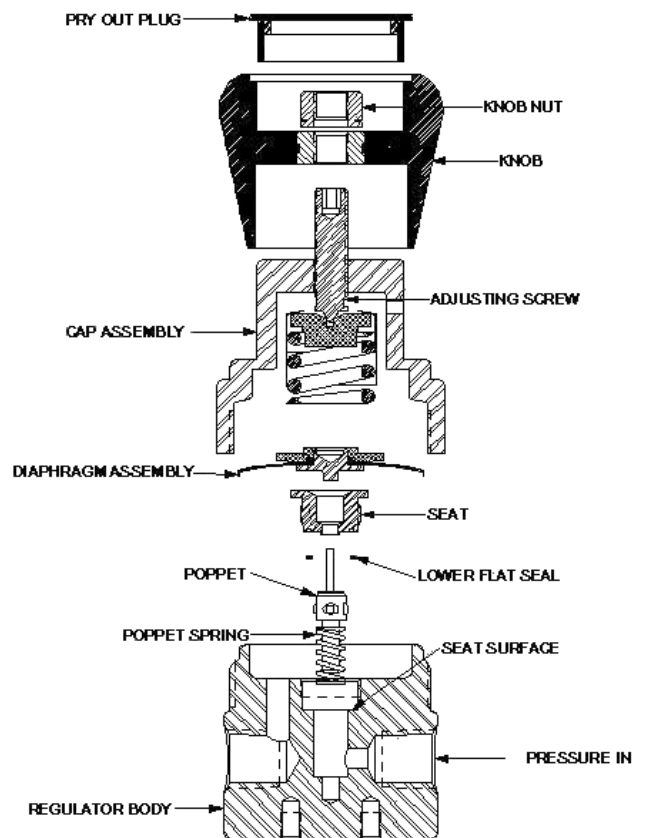

21. Place new diaphragm assembly onto regulator cavity.
22. Place range spring and spring button onto diaphragm assembly unless it was equipped with a stabilizer and is inside the cap.
23. Place a small amount of Krytox or other lubricant on the outer threads of the body if the regulator body is steel. Do not apply lubricant to threads if regulator body is brass.
24. Put the cap over the regulator and engage threads by hand. Tighten hand tight.
25. Finish tightening cap to 60 lbf•ft (81 N•m). (40 lbf•ft (54 N•m) with Teflon / Viton diaphragm).
26. Attach a pressure gauge and quarter-turn valve to the outlet port. Leave the valve in the open position.
27. Use a 5/32" Allen wrench and slowly turn adjusting screw clockwise. When there is evidence of flow at the quarter-turn valve close it.
28. Squirt a leak detecting fluid around the base of the cap where it meets the body. Agitate the fluid to form foam and apply around the 0.125 (3.1mm) leak detection port in the bonnet of the cap.
29. Slowly continue turning the adjusting screw while watching and listening for any leaks. It may be necessary to re-apply the liquid. If leaks are noticed, immediately back off adjusting screw and repair unit as needed.
30. If no leaks are noticed, adjust control pressure to a value that is 110% of the maximum rating for this regulator. Reapply the leak detecting fluid as needed.
31. Note the pressure reading on the gauge. Wait for 5 minutes. Increasing pressure indicates a leak across the seat or flat seal. Decreasing pressure indicates a possible diaphragm leak. If the pressure does not remain stable, the unit must be disassembled and the cause of leakage repaired.
32. Spin the knob as far down as it will go on the adjusting screw.
33. Tighten the knob nut against the metal insert, being careful not to change the position of the knob while doing this.
34. Relieve the outlet pressure while backing off on the adjusting knob. Continue backing off on adjustment knob until it is all the way out and will turn no further.
35. Install pry-out plug into top of knob.
36. The regulator is now ready for service.

GO Regulator

405 Centura Court • PO Box 4866 • Spartanburg, SC 29303

Phone (864) 574-7966 • Fax (864) 574-5608

www.goreg.com • sales@goreg.com