

PR-7 Series Pressure Regulator Diaphragm Replacement Instructions

Make sure you thoroughly understand these directions before proceeding
MAKE SURE THE REGULATOR IS DISCONNECTED FROM AIR SOURCE
MAKE SURE ANY RESIDUAL PRESSURE IS BLED OFF FROM REGULATOR.

Instructions

1. Completely read these instructions before performing any of the operations.
2. Make sure the regulator is disconnected from pressure source; make sure any residual pressure is bled off from the regulator. **FAILURE TO DO THIS WILL RESULT IN SERIOUS PERSONAL INJURY. DO NOT PROCEED UNTIL PRESSURE HAS BEEN REMOVED AND/OR TERMINATED** Securely clamp the regulator over the flats in a vise.
3. Turn the knob counterclockwise as far as it will go. This should allow enough room for a standard adjustable end wrench to fit on the flats of the cap. Otherwise you will have to remove the pry-out plug from top of knob, remove knob nut and unscrew knob from adjusting screw.
4. Remove the cap and adjusting screw as a unit. The diaphragm will probably remain in the cap when it is removed. The range spring will be securely held inside the cap if this unit is equipped with a spring stabilizer. Earlier models do not have a stabilizer, in which case the range spring will come out when the diaphragm is removed.
5. If the diaphragm assembly remained in the cap you will have to rotate the adjusting screw clockwise to force it out. Gently rock the diaphragm assembly back and forth while turning the adjusting screw. This will facilitate the removal of the diaphragm assembly.
6. Place new diaphragm assembly onto the nose of the regulator. **DO NOT** insert a new diaphragm assembly back into the cap assembly.
7. Place range spring and spring button onto diaphragm assembly unless it was equipped with a stabilizer and is inside the cap.
8. Place a small amount of Krytox or other lubricant on the outer threads of the body if the regulator body is steel. Do not apply lubricant to threads if regulator body is brass.
9. Put the cap over the regulator and engage threads by hand. Tighten hand tight.
- 10.

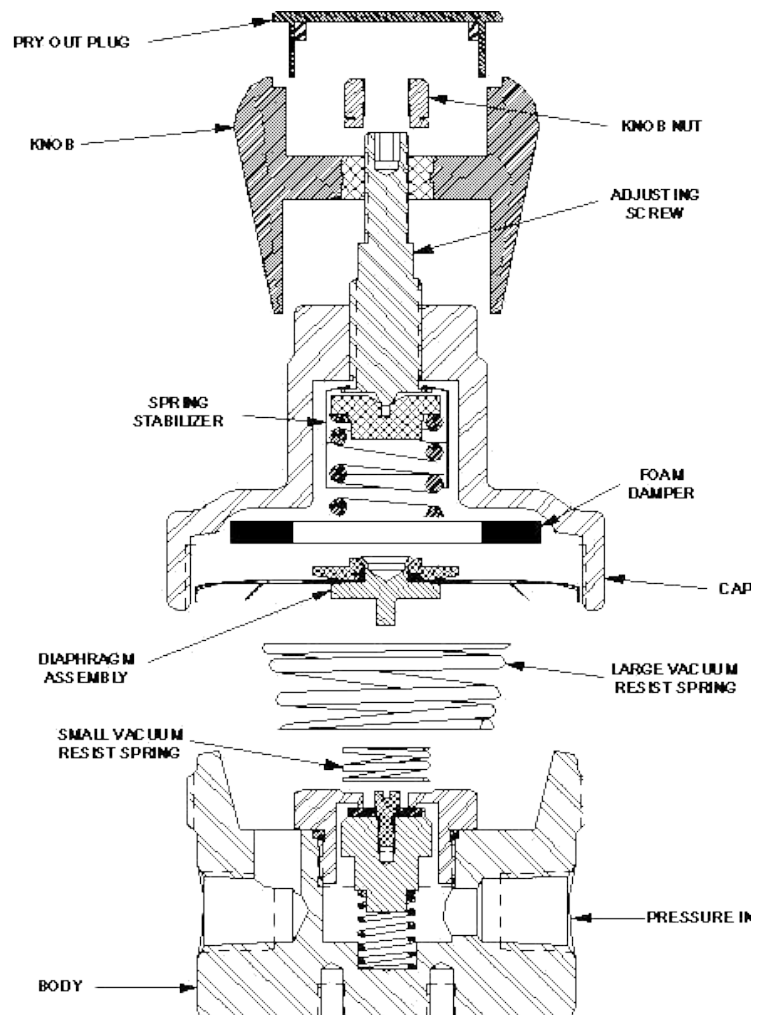

11. Finish tightening cap to 60 lbf·ft (81 N·m). (40 lbf·ft (54 N·m) with teflon / viton diaphragm). Attach a pressure gauge and quarter-turn valve to the outlet port. Leave the valve in the open position.
- 12.
13. Slowly turn adjusting screw clockwise. When there is evidence of flow at the quarter-turn valve close it.
- 14.
15. Squirt a leak detecting fluid around the base of the cap where it meets the body. Agitate the fluid to form foam and apply around the 0.125 (3.1mm) leak detection port in the bonnet of the cap.
16. Slowly continue turning the adjusting screw while watching and listening for any leaks. It may be necessary to re-apply the liquid. If leaks are noticed, immediately back off adjusting screw and repair unit as needed.
17. If no leaks are noticed, adjust control pressure to a value that is 110% of the maximum rating for this regulator. Reapply the leak detecting fluid as needed.
18. Note the pressure reading on the gauge. Wait for 5 minutes. Increasing pressure indicates a leak across the seat or flat seal. Decreasing pressure indicates a possible diaphragm leak. If the pressure does not remain stable, the unit must be disassembled and the cause of leakage repaired.

If knob was removed:

- Spin the knob as far down as it will go on the adjusting screw.
 - Tighten the knob nut against the metal insert, being careful not to change the position of the knob while doing this.
 - Install pry-out plug into top of knob.
19. Relieve the outlet pressure while backing off on the adjusting knob. Continue backing off on adjustment knob until it is all the way out and will turn no further.
 20. The regulator is now ready for service.

GO Regulator

405 Centura Court • PO Box 4866 • Spartanburg, SC 29303

Phone (864) 574-7966 • Fax (864) 574-5608

www.goreg.com • sales@goreg.com