

## DHR Series

Electrically Heated Dual Pressure Regulators

### Introduction

The Dual Heated Pressure Regulator is designed to supply heat to samples entering instrumentation systems. It can be used to preheat liquids, to prevent condensation of gases or to vaporize liquids prior to gas analysis. Significant space savings can be realized due to the utilization of two discrete regulators that are heated by a common source.

The modular design of the Dual Heated Regulator consists of a heating element and pressure control sections. The pressure control sections are patterned after the time proven design of the PR-1 pressure reducing regulator and provides the same excellent outlet pressure stability. The heat exchanger section is made up of a body and a heating element.

The Dual Heated Pressure Regulators are ATEX approved. The electrical components of this unit are securely housed in a Class A, B, C, D conduit assuring that there is always an adequate flame path between the environment and the controller. Safety considerations can be further enhanced by using the optional TCO (Thermal Cut Out) heater cartridge and proportional controller. These features enable the unit to boast a T3 rating with 150 watts of power.



### Typical Applications

#### Analytical process sample conditioning systems:

- Petrochemical refineries
- Chemical production facilities
- Pilot plants (chemical & petrochemical)
- LNG loading and off-loading points
- Natural gas pipeline sampling

### Technical Data

CONSTRUCTION	316L stainless steel
OUTLET PRESSURES	0–10, 0–25, 0–50, 0–100, 0–250, and 0–500 psig
OPERATING TEMPERATURE	up to 380° F (193° C)
HEATING CAPACITY RANGES (IN WATTS)	40, 50, 100, and 150
C <sub>v</sub> COEFFICIENTS	0.06, 0.025, 0.2
CERTIFICATIONS	ATEX Directive 94/9/EC Certification # TRL03ATEX11001X

### Features & Benefits

- Optional Hastelloy® C-276 and Monel®
- Electropolished body with better than 25 Ra finish in diaphragm cavity for an optimal sealing surface
- Bubble-tight shutoff
- Available in 120VAC or 240VAC
- Optional TCO heating cartridge and proportional controller

pressure regulators

### GO Regulator

405 Centura Court • PO Box 4866 (29305) • Spartanburg, SC 29303  
Phone (864) 574-7966 Fax (864) 574-5608  
www.goreg.com • sales@goreg.com

# DHR Series

## How to Order

Standard items in bold

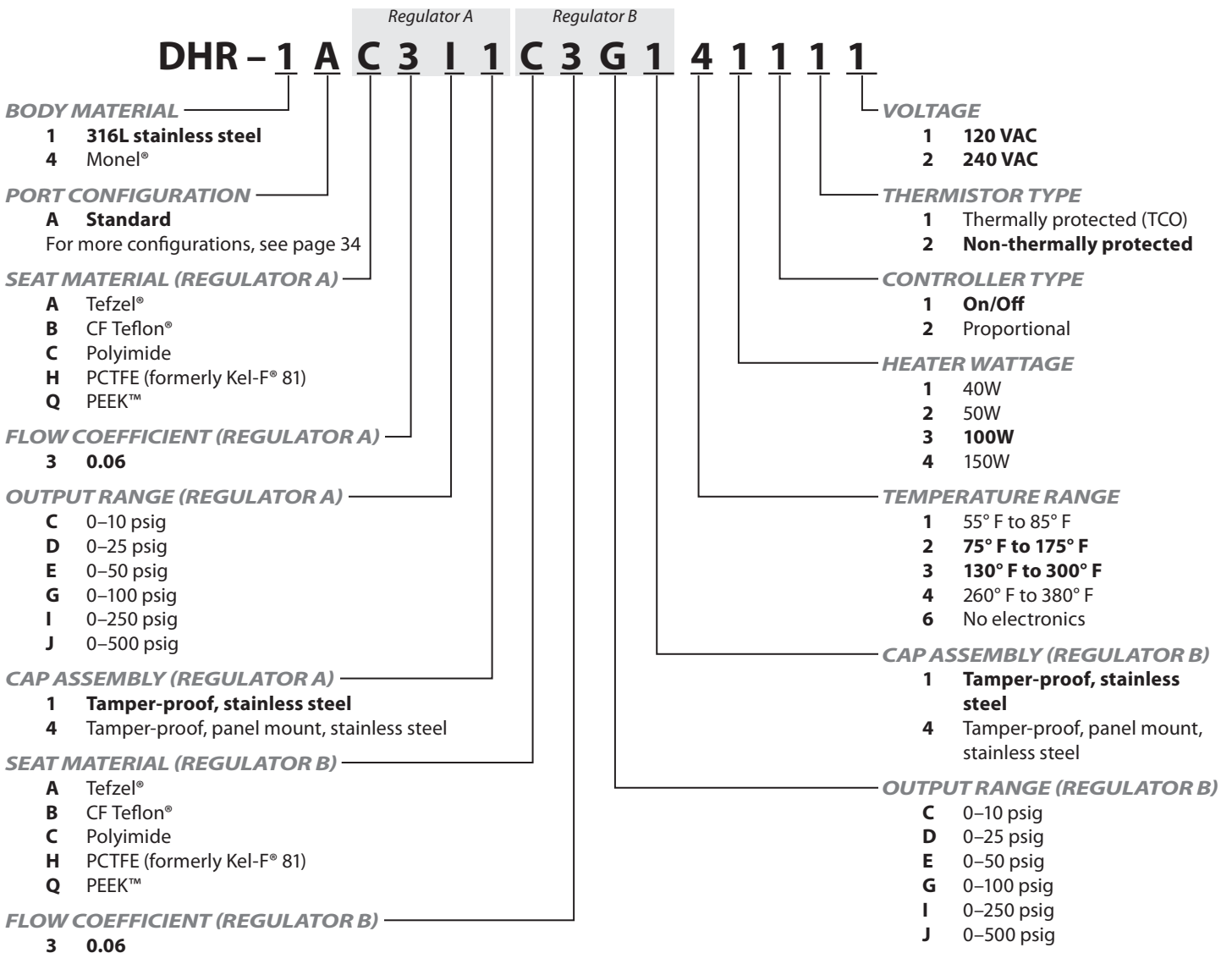

*NOTE: The choices above represent an abbreviated list of the more commonly ordered options. For a complete listing of all available options, please see the Selection Wizard on the GO website at [www.goreg.com](http://www.goreg.com) or contact the factory.*

## Maximum Temperature & Operating Inlet Pressures

SEAT MATERIAL	MAXIMUM PRESSURE	@	MAXIMUM OPERATING INLET PRESSURE
Tefzel®	Up to 175° F (80° C)	@	3600 psig (24.82 MPa)
	176° F to 300° F (80° C to 148° C)	@	1000 psig (6.90 MPa)
	301° F to 380° F (148° C to 193° C)	@	400 psig (2.76 MPa)
High density Teflon®	Up to 175° F (80° C)	@	3600 psig (24.82 MPa)
	176° F to 300° F (80° C to 148° C)	@	1000 psig (6.90 MPa)
	301° F to 380° F (148° C to 193° C)	@	400 psig (2.76 MPa)
PCTFE (formerly Kel-F®)	Up to 380° F (193° C)	@	3600 psig (24.82 MPa)
Polyimide	Up to 380° F (193° C)	@	6000 psig (41.37 MPa)
PEEK™	Up to 380° F (193° C)	@	6000 psig (41.37 MPa)

# DHR Series

## Outline and Mounting Dimensions

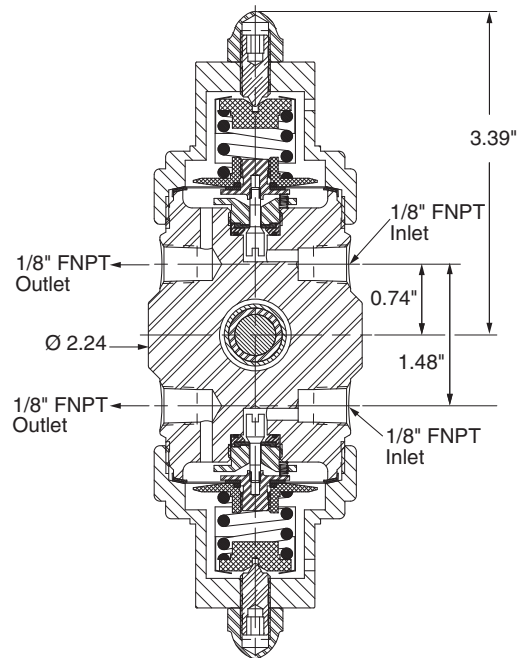
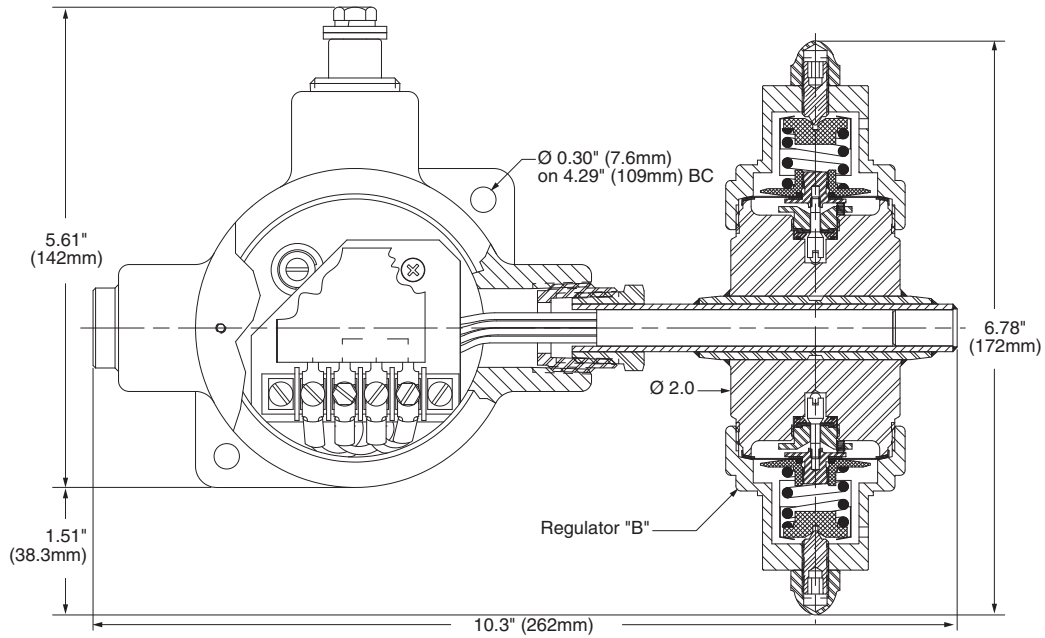

# Porting Configurations for DHR Steam & Electric Series

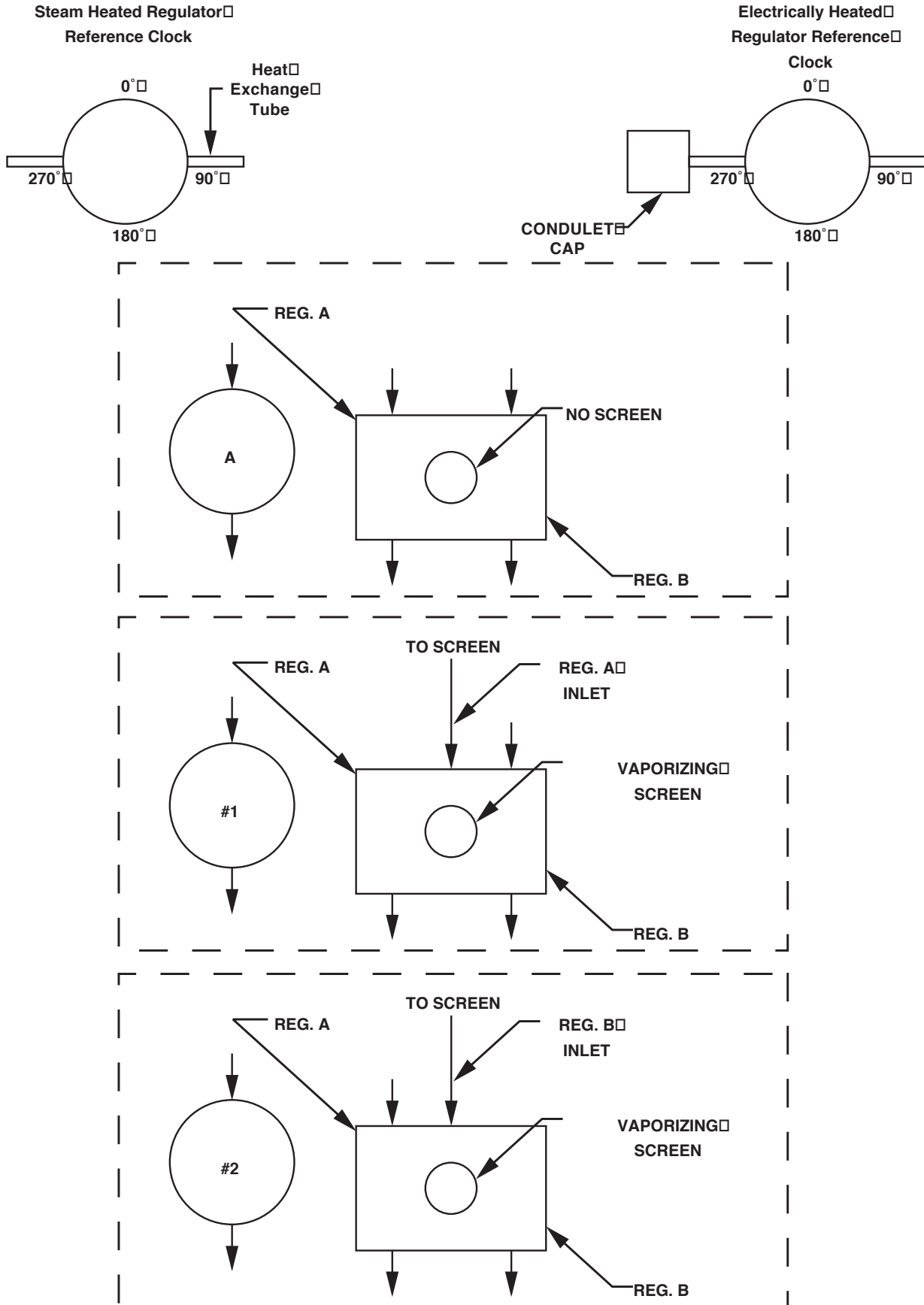

Location of ports from to of regulator "A". Arrow pointing toward body is inlet. Arrow pointing away from body is outlet.

## ***For Your Safety***

---

It is solely the responsibility of the system designer and user to select products suitable for their specific application requirements and to ensure proper installation, operation, and maintenance of these products. Material compatibility, product ratings and application details should be considered in the selection. Improper selection or use of products described herein can cause personal injury or property damage.

*Hastelloy® is a registered trademark of Haynes International, Inc.  
Monel® is a registered trademark of Special Metals Corporation.  
Teflon® and Tefzel® are registered trademarks of the DuPont Company.  
Kel-F® is a registered trademark of 3M Company.  
PEEK™ is a trademark of Victrex PLC.  
Viton® is a registered trademark of DuPont Dow Elastomers.*